

# BeoLink Wireless 1

Guide

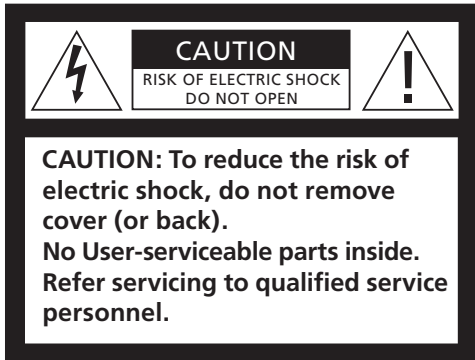

**WARNING:** To reduce the risk of fire or electric shock, do not expose this appliance to rain or moisture. Do not expose this equipment to dripping or splashing and ensure that no objects filled with liquids, such as vases, are placed on the equipment.

To completely disconnect this equipment from the AC Mains, disconnect the mains plug from the wall socket. The disconnect device shall remain readily operable.



The lightning flash with arrowhead symbol within an equilateral triangle, is intended to alert the user to the presence of un-insulated “dangerous voltage” within the product’s enclosure that may be of sufficient magnitude to constitute a risk of electric shock to persons.



The exclamation point within an equilateral triangle is intended to alert the user to the presence of important operating and maintenance (servicing) instructions in the literature accompanying the product.

This class B digital apparatus meets all requirements of the Canadian Interference-Causing Equipment Regulations.

The internal antennas used for this mobile transmitter must provide a separation distance of at least 20 cm (8”) from all persons, and must not be co-located or operating in conjunction with any other antenna or transmitter.

Modifications not expressly approved by this company could void the user’s authority to operate the equipment.

NOTE: This device complies with part 15 of the FCC Rules. Operation is subject to the following two conditions: (1) This device may not cause harmful interference, and (2) this device must accept any interference received, including interference that may cause undesired operation.

This equipment generates, uses and can radiate radio frequency energy and, if not installed and used in accordance with the instructions, may cause harmful interference to radio communications. However, there is no guarantee that interference will not occur in a particular installation. If this equipment does cause harmful interference to radio or television reception, which can be determined by turning the equipment off and on, the user is encouraged to try to correct the interference by one or more of the following measures:

- Reorient or relocate the receiving antenna.
- Increase the separation between the equipment and receiver.
- Connect the equipment into an outlet on a circuit different from that to which the receiver is connected.
- Consult the retailer or an experienced radio/TV technician for help.

**Introduction, 4**

This chapter provides you with an overview of the Wireless 1 system in the main room and the link room and describes the Master Link and Power Link setups.

**Close-up operation, 6**

Find out how to switch on the Timer Play function and 'listen in' on a source playing on the main room system.

**Beo4 remote control, 7**

Find out how to use the Beo4 remote control to access main room sources in a link room.

**Beo4 – Sound adjustments, 8**

Find out how to use the Beo4 remote control to adjust sound settings.

**Set up BeoLink Wireless 1, 9**

Information about placement, installation and connections of the Wireless 1 units and the 'IR-eye'.

**Ready for use ..., 16**

Information about making your link room products ready for use.

## Introduction

The *main room* is the room in which you have placed the audio and/or video system – complete with their various sources (the main system). Connected to the main system, you will need a BeoLink Wireless 1 set up as *transmitter*.

The *link room* is where you have set up another BeoLink Wireless 1 as *receiver*. To complete the link room setup, you will need either a Bang & Olufsen audio/video product, or a pair of active speakers.

*Depending on the type of your link room product, your link room system requires either a Master Link setup or a Power Link setup.*

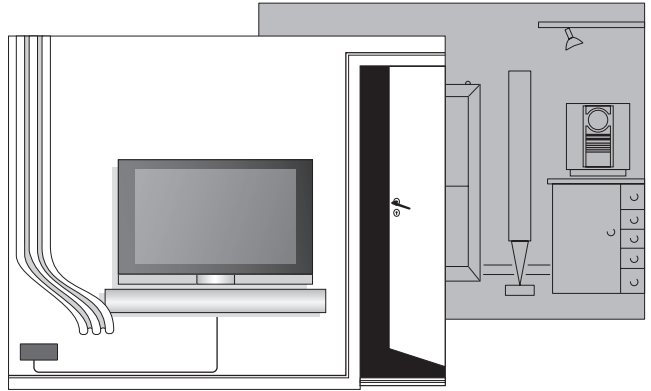

*Link room system with a compatible video product – set up with a Master Link connection.*

### Master Link setup

If your link room product is either an audio or a video system, it must be connected to BeoLink Wireless 1 with a *Master Link* cable.

*Note that a BeoLab 3500 setup must also be connected to BeoLink Wireless 1 with a Master Link cable.*

For operation of such a setup, refer to the Guide enclosed with your link room product.

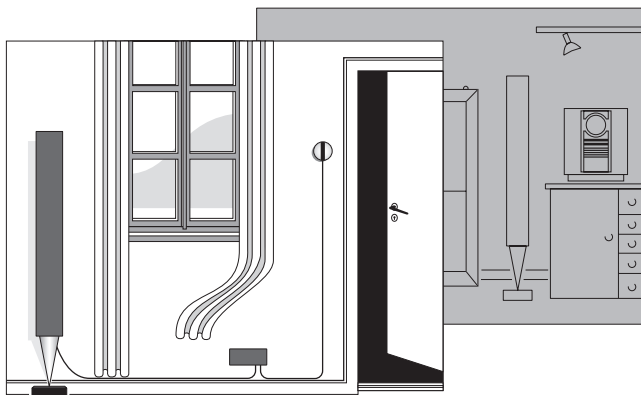

*Link room system with active speakers and an 'IR-eye' – set up with a Power Link connection .*

For information about installation of the BeoLink Wireless 1 system, refer to 'Set up BeoLink Wireless 1' (pp. 9–15) in this Guide.

For information about how to set up the main room system and the link room products, refer to the Guides enclosed with the products.

### **Power Link setup**

If your link room product is a pair of active speakers, they must be connected to BeoLink Wireless 1 with *Power Link* cables.

For operation of such a setup, refer to pp. 6–8 in this Guide.

This setup also requires an 'IR-eye', in order to be able to operate the system – either by close-up operation, or with a Bang & Olufsen remote control.

## Close-up operation

*This page concerns only a Power Link setup with an 'IR-eye'. For information about close-up operation of link room products set up with Master Link cables, refer to the Guides enclosed with the products.*

The small circular 'IR-eye' has buttons for close-up operation.

You can use the buttons to listen-in on a source currently playing on the main system.

You can also use the buttons to adjust the sound volume.

The buttons can also be used to include or exclude the link room speakers in a Timer Play programmed on the main audio or video system.

*The Timer Play function is not available in all Bang & Olufsen systems. Please refer to the Guide for your main system.*

*Listen-in on a main room source*

- > Press **PLAY** • to listen-in on a source that is currently playing in your main system. If no source is playing when you press **PLAY** •, the radio in the main system will be switched on. If the main system have no audio sources, it will switch on the TV program that was last playing.
- > Press **PLAY** • again, and the link room speakers switch off (a red standby indicator appears in the **PLAY** • button).

If you keep the **PLAY** • button pressed for more than two seconds, both the link room and your main system switch off.

### *Volume adjustment*

- > Press **^** or **v** to raise or lower the volume level in the loudspeakers.

The volume level in the link room speakers is adjusted independently of your main system.

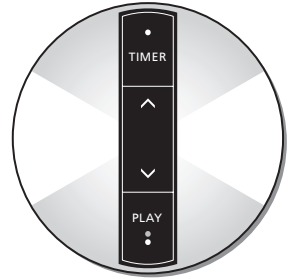

### *Timer Play control*

If the main system is programmed to start playing automatically (Timer Play), the link room speakers can be included as well.

- > Press **TIMER**. A small red light in the **TIMER** button indicates that the link room speakers will be included.
- > Press **TIMER** again to cut out the Timer function for the link room (the red light disappears).

*This page concerns only a Power Link setup with an 'IR-eye'. For information about Beo4 remote control operation of link room products set up with Master Link cables, refer to the Guides enclosed with the products.*

With the Beo4 remote control you can switch on the sources from your main audio or video system you wish to listen to, and you can control functions for those sources – just as if you were operating your main system directly.

*Functions mentioned here are only available via BeoLink Wireless 1 if the source in question is present in your Bang & Olufsen system and the source supports the function.*

*To switch on an Audio source ...*

- > Press **RADIO** to listen to a radio programme.
- > Press **CD** to listen to a CD.
- > Press **A MEM (A TAPE)** to listen to an audio recording.

*To switch on a Video source ...*

- > Press **TV** to listen to TV.
- > Press **DTV (SAT)** to listen to digital TV.
- > Press **V MEM (V TAPE)** to listen to a video recording.
- > Press **DVD** to listen to a DVD.

*To switch on additional sources ...*

- > Press **LIST** to display additional sources, such as **N.MUSIC** (music stored on a PC), and then press **GO** to switch on a source.

*Refer to the Guides supplied with Beo4 and the audio and video system for further information on their operation.*

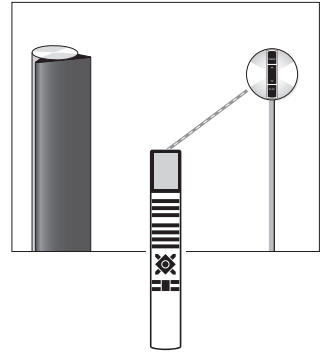

*The Beo4 remote control is available as an optional extra from a Bang & Olufsen retailer.*

## Beo4 – Sound adjustments

*This page concerns only a Power Link setup with an 'IR-eye'. For information about sound adjustments of link room products in Master Link setups, refer to the Guides enclosed with the products.*

With the Beo4 remote control you can adjust the sound coming out of the link room speakers.

All sound levels are reset to their original values when you switch off the link room – unless you store them permanently.

All the current sound levels, including volume level, are stored simultaneously.

The sound is adjusted independently from the main audio or video system.

*To adjust sound volume or mute the sound ...*

- > Press  $\wedge$  or  $\vee$  to adjust the sound volume up or down.
- > Press the middle of the  $\wedge\vee$  button to mute the sound, and press  $\wedge$  or  $\vee$  to restore the sound.

*To adjust speaker balance ...*

- > Press LIST repeatedly until SPEAKER\* is shown in the display.
- > Press  $\blacktriangleleft$  or  $\blacktriangleright$  to adjust balance left or right.

*To adjust bass, treble or loudness ...*

- > Press LIST repeatedly until A.SETUP\* (or V.SETUP\* for a video source) is shown in the display.
- > Press GO to be able to adjust settings.
- > Press LIST repeatedly until BASS, TREBLE or LOUDNSS is shown in the display.
- > Press  $\blacktriangle$  or  $\blacktriangledown$  to adjust the setting.
- > Press GO to select the setting.

*To store sound settings permanently – making a new preset start-up level ...*

- > Press LIST repeatedly until S.STORE\* is shown in the display.
- > Press GO to store settings permanently.

\*NOTE! In order to display these functions, you must first add them to the Beo4 list of functions. Refer to the chapter 'Customising your Beo4' in the Beo4 Guide.

On the next pages is explained how to install a set of BeoLink Wireless 1 – both in the main room and in a link room.

*We recommend that you follow this procedure:*

- Set up connection between the Wireless 1 units as explained on p. 10.
  - Make the cable connections as explained on pp. 12-14.
  - Check the wireless connection between the main room and link room setups.
  - If necessary, fasten the units to the wall as explained on pp. 11 and 15.
  - Set the link room setup to the correct Option as explained on p. 16.
- Before you start ...**
- Make sure that Wireless 1 is set up in accordance with the instructions in this Guide. To prevent injury, use Bang & Olufsen approved wall brackets only!
  - Wireless 1 can only be switched off completely by disconnecting it from the wall socket.
  - Do not attempt to open Wireless 1. Leave such operations to qualified service personnel!
  - Wireless 1 is designed for indoor use in dry, domestic environments only, and for use within a temperature range of 10–45° C (50–113° F).
  - Leave enough space around Wireless 1 for adequate ventilation.
  - Do not place any items on Wireless 1.
  - Depending on the placement and surroundings, Wireless 1 has an indoor range of approximately 30 m (100').
- One transmitter can serve up to seven receivers, and you can only install three transmitters in a setup.
  - The transmitters must be placed at least 5 m (16') apart.
  - You will need at least *one* BeoLink Wireless 1 set up as a transmitter connected to the main system, and one BeoLink Wireless 1 set up as a receiver in each link room. Furthermore, you will need an 'IR-eye' in each link room with a Power Link setup.
  - Do not place the 'IR-eye' in direct sunlight or direct artificial light (a spotlight, for example), or near objects generating electrical noise (such as light dimmers), as this may reduce the sensitivity of the remote control receiver.

**Wireless 1 – Transmitter/  
receiver ...**

Wireless 1 must be set up as either transmitter or receiver. Before fastening the transmitter and receiver to the wall, you must establish connection between them. This must be done while the units are located in the same room.

The connection procedure described here must be performed for each receiver in a setup – one at a time.

If more than one transmitter is necessary, connection must be established between each transmitter and each receiver – one by one. Only *one* transmitter at a time must be switched on, while you set up connection to the receivers.

**To set up connection between a  
transmitter and a receiver ...**

- > Set the two-position switch to transmit or receive (T or R), respectively.
- > Connect the transmitter and the receiver to the mains supply.
- > Press the connection button on the transmitter and the receiver to start a one-minute connection mode.
- > When the indicator shines green or yellow, connection between the transmitter and the receiver is established. Approximately 20 seconds after connection has been established, the receiver switches to standby (indicator shines red).
- > When the receiver switches to standby, disconnect the units from the mains supply, and move them to their future positions.

If you have more receivers, repeat the above procedure for each receiver.

**Light indications**

**Fast yellow flash ...** Wireless 1 is reset to factory setting.

**Slow red flash ...** Wireless 1 is in connection mode.

**Fast red flash ...** Connection failed/receiver out of range of the transmitter.

**Green ...** Connection between the transmitter and receiver is good.

**Yellow ...** Connection between the transmitter and receiver is acceptable, but not optimal.

**Red ...** Receiver switched to standby.

*To reset Wireless 1 to factory setting (no connection), press and hold the connection button until the yellow indicator starts to flash fast.*

*On page 11 is shown how to get access to the buttons and sockets.*

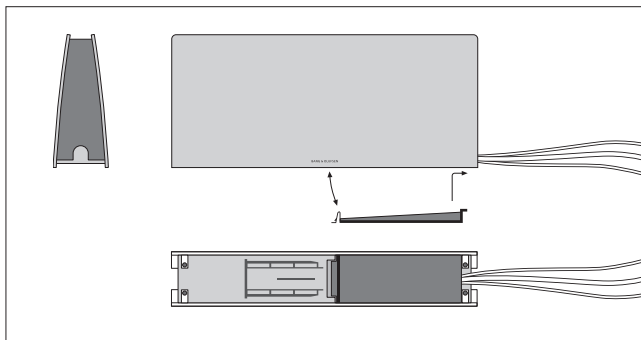

### Wireless 1 – wall mount

Wireless 1 can be fastened to a wall (or ceiling) with one of the two enclosed brackets – in either a horizontal or a vertical position. It can be placed on the bracket so that the cables may be run either to the left or to the right. *However, if you place Wireless 1 vertically on a wall, the cables must be run downwards – otherwise the bracket will not hold Wireless 1 safely!*

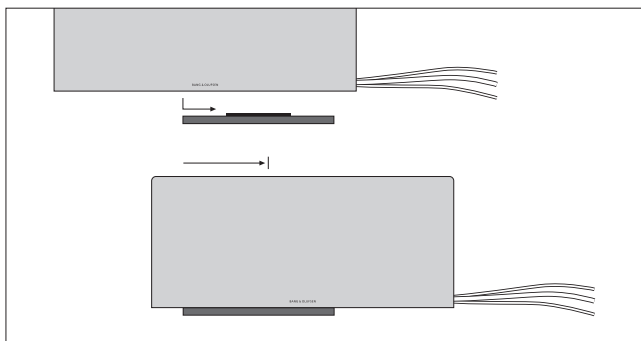

Use two screws and wall anchors, each with a minimum load rating of 1.6 kg (3.5 lbs.). However, if you intend to hang Wireless 1 from a gypsum wall or ceiling, one screw must be a lag screw (4 mm – 0.15"), which penetrates the gypsum, and is screwed a minimum of 12 mm (0.5") into a vertical stud. The other screw must be of a type intended for gypsum panels.

*To get access to the connection button and sockets, you must first remove the cover. When you have connected the cables and checked that the wireless connection is still intact, run the cables through the groove and put on the cover again.*

*When you have put on the cover, slide Wireless 1 onto the bracket as shown.*

### Connections – Master Link

**In the main room:** Connect the transmitter to the Master Link socket on the main system. Then connect both the main system and transmitter to the mains supply.

**In the link room:** Connect the audio or video product to the Master Link socket on the receiver. Then connect both the audio or video product and the receiver to the mains supply.

Check the indicator light in the receiver to ensure that connection is still intact. If the connection is lost, the units must be moved. The receiver switches to standby after approximately 20 seconds.

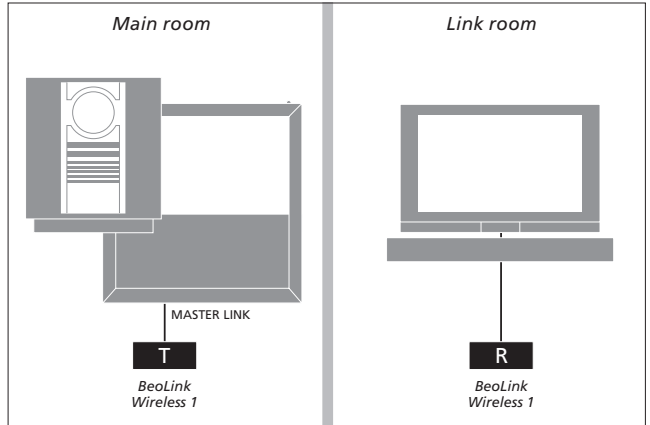
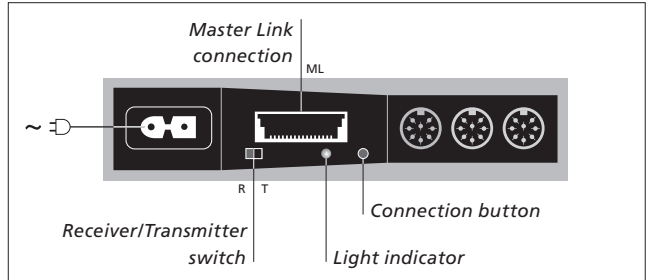

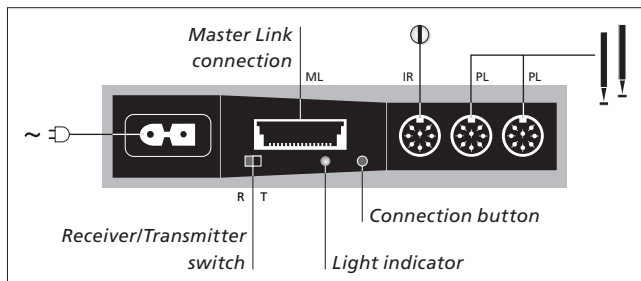

### Connections – Power Link

**In the main room:** Connect the transmitter to the Master Link socket on the main system. Then connect both the main system and transmitter to the mains supply.

**In the link room:** Connect the loudspeakers to the Power Link sockets on the receiver. Connect the 'IR-eye' to the socket marked IR (for information about the 'IR-eye' and its cable, see p. 14). Then connect both the loudspeakers and the receiver to the mains supply.

Check the indicator light in the receiver to ensure that connection is still intact. If the connection is lost, the units must be moved. The receiver switches to standby after approximately 20 seconds.

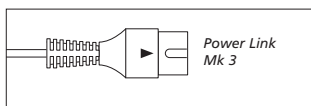
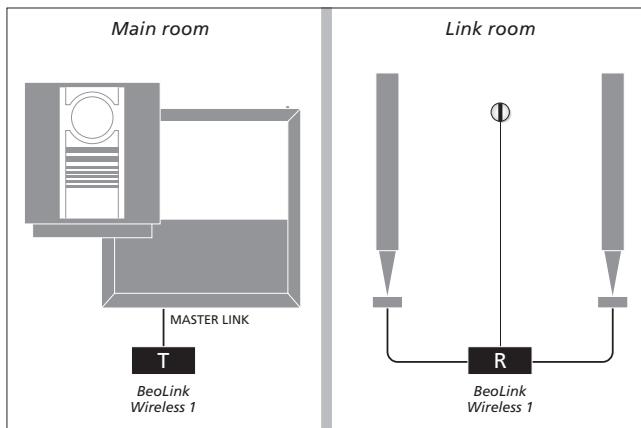

**Power Link cables:** *The cables must be of the type which are marked with a triangle on the plug. Do not use any of the old type of Power Link cables, as this will cause noise, and thus not give optimum sound quality!*

**'IR-eye' – cable connections**

The small circular 'IR-eye' is available from a Bang & Olufsen retailer. An 'IR-eye' must be used in each link room with a Power Link setup. Use the cable supplied with the 'IR-eye' and connect it as explained here:

- > Cut the cable to the required length (from the receiver to the 'IR-eye') and strip it as shown.
- > Insert the cable end through the cable clamp (A) and connect the leads to the terminals inside the 'IR-eye' in the order indicated. Then tighten the clamp (A).
- > Attach the rear cover and fix the 'IR-eye' to the wall as explained on the next page – and then plug the cable into the socket marked IR on the receiver.

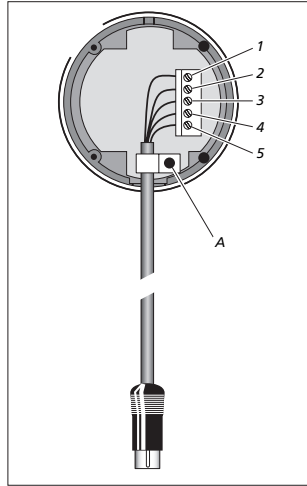

Connect the leads in the cable to the terminals inside the receiver in this order:

- 1 = Yellow
- 2 = Grey
- 3 = Green
- 4 = White
- 5 = Brown

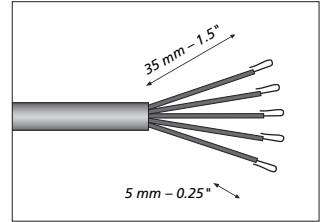

Strip the cable end. Twist the cores in each lead and bend them back.

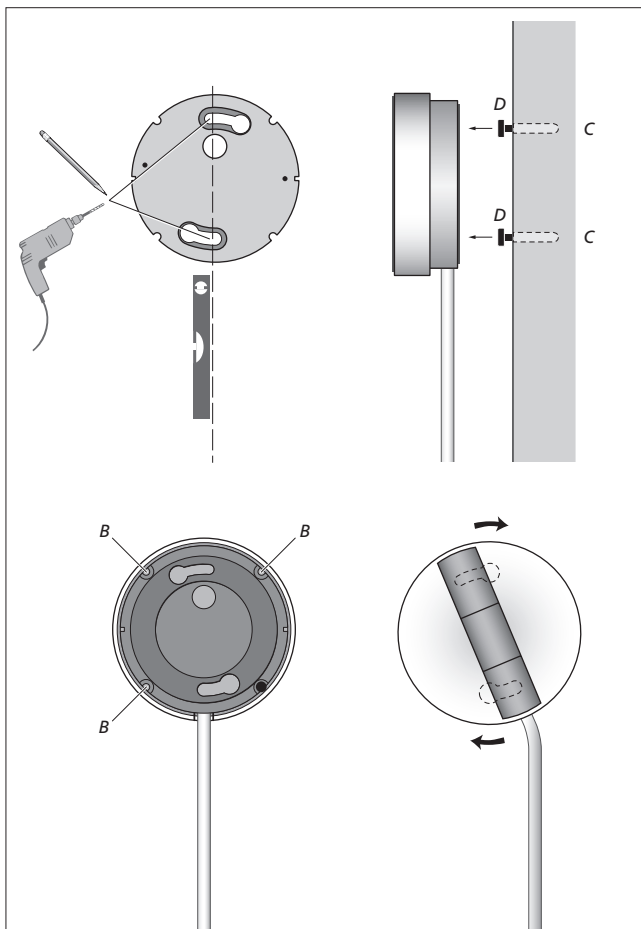

### 'IR-eye' – wall mount

If the 'IR-eye' is placed next to a door and at a suitable height, you can easily switch on or off by close-up operation when entering or leaving the room. Likewise, if it is placed near your telephone, you can switch off the speakers while you are on the phone.

- > Use the wall plate as a template to mark up the holes on the wall. Insert the screws and wall anchors, but let the two screw heads protrude from the wall as shown (C/D).
- > Place the wall plate onto the rear of the 'IR-eye', and fasten it with the three screws (B).
- > Insert the two protruding screw heads (D) into the corresponding 'keyholes', and turn the 'IR-eye' clockwise to fasten it.

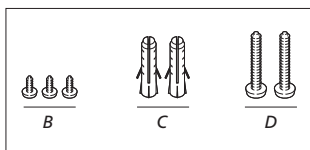

## Ready for use ...

### Option settings

When you have made all the connections as described on the previous pages or in the Guides enclosed with your link room products, you may start to use the system. However, in order for your setup to function properly, you must Option program your link room products.

On this page you can find out which Options to use in your Power Link setup. For information about Option settings for a link room product in a Master Link setup, refer to the Guides enclosed with the products.

*In a Power Link setup set the link room speakers to one of the following Options:*

**Option 0:** Used if you want to disable remote control operation in the link room.

**Option 4:** Used if you install a link room setup in the same room as your main system (for example in a large L-shaped room with two separate listening positions).

**Option 5:** Used if you set up a Bang & Olufsen television in the link room.

**Option 6:** Used in a setup with the main system in one room, and the link room setup in another – as described in this guide (this is the factory setting).

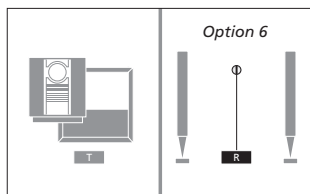
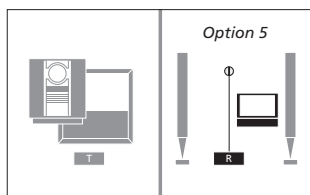
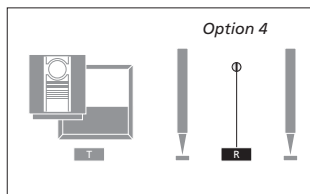

*Use a Beo4 remote control to set the Option. The entire system must be switched to standby:*

- > While holding down the • button, press **LIST**.
- > Let go of both buttons.
- > Press **LIST** repeatedly until **OPTION?** is shown in the Beo4 display, and press **GO**.
- > Press **LIST** repeatedly until **L.OPT** is shown in the Beo4 display, and then key in the appropriate number (**0, 4, 5, or 6**).

### **Wireless interference**

Signals between the transmitter and receiver can be influenced by other systems, such as microwaves or wireless pc systems, as well as wireless telephone systems in the USA. If interferences occur, you should try to correct it by one or more of the following measures:

- Reorient or relocate the receiver to improve reception.
- Increase separation between the disturbing equipment and the receiver.
- Consult your Bang & Olufsen retailer for assistance.



### **Waste Electrical and Electronic Equipment (WEEE) – Environmental protection**

The European Parliament and the Council of the European Union have issued the Waste Electrical and Electronic Equipment Directive. The purpose of the Directive is the prevention of waste of electrical and electronic equipment, and to promote the reuse and recycling and other forms of recovery of such waste. As such the Directive concerns producers, distributors and consumers.

The WEEE directive requires that both manufacturers and end-consumers dispose of electrical and electronic equipment and parts in an environmentally safe manner, and that equipment and waste are reused or recovered for their materials or energy.

Electrical and electronic equipment and parts must not be disposed of with ordinary household refuse; all electrical and electronic equipment and parts must be collected and disposed of separately.

Products and equipment which must be collected for reuse, recycling and other forms of recovery are marked with the pictogram shown.

When disposing of electrical and electronic equipment by use of the collection systems available in your country, you protect the environment, human health and contribute to the prudent and rational use of natural resources. Collecting electrical and electronic equipment and waste prevents the potential contamination of nature with the hazardous substances which may be present in electrical and electronic products and equipment.

Your Bang & Olufsen retailer will assist with and advise you of the correct way of disposal in your country.



*This product is in conformity with the provisions of the Directives 1999/5/EC and 2006/95/EC.*

*This product may be used in member states of the EEU and EFTA.*

*Technical specifications, features and the use thereof are subject to change without notice!*

